



 OktaLine™

**The Power Pump Portfolio.
Roots Pumps for Every Low and Medium Vacuum Application.**

**The Power Pump Portfolio.
Roots Pumps for Every Low and Medium Vacuum Application.**

**A complete line of
powerful pumps**

Our Roots pumps offer pumping speeds ranging from 250 to 25,000 m³/h. They can be safely employed for low and medium vacuum applications in the coating or semiconductor industry, in research & development, metallurgy or in chemistry and process technology.

The gear box and bearing area in our Roots pumps are separated from the gas pumping chamber. Because the rotors operate contactfree, dry operation is assured.

A further advantage: Thanks to air cooling, operating costs are significantly lower than with water cooling. The pumps can be universally utilized.

The design principle of our proven Roots pumps has also been expanded to include magnetic couplings. Thanks to these hermetically sealed pumps we achieve very low leak rates. We have also developed ATEX certified pumps for processes that take place in explosive environments or for evacuating explosive gases.

With our CombiLine™, we design and manufacture standard pumping stations for you, as well as custom solutions for your specific application. Our specialists would be pleased to assist you in designing your vacuum system.

**Pfeiffer Vacuum Roots
pumps – Just right for your
application!**

With our reliable products, our decades of experience and our know-how, we stand ready to provide you with the optimum solution for your low and medium vacuum needs.



Metallurgy



Air recovery



Glass coating



Advantages at a glance

- Complete line of Roots pumps offers optimum flexibility and maximum process suitability
- Broad range of pumping speeds: 250 to 25,000 m³/h
- Rugged, compact design
- Fast evacuation thanks to high compression ratio and overflow valve
- Maintenance free, maximum reliability and highest uptime thanks to magnetic coupling
- Low operating costs thanks to air cooling and magnetic coupling
- No thermal overload thanks to integral overflow valve
- Long service intervals and simple on-site maintenance
- On-site service worldwide
- Over 50 years of experience and competence

The Power Pump Portfolio. Roots Pumps for Every Low and Medium Vacuum Application.

Applications

- Metallurgy
- Simulation chambers
- Packaging industry
- Freeze/vacuum-drying
- Thin-film technology
- Electron beam welding
- Load-locks
- Chemistry and process technology
- Industrial leak detection systems
- Steel degassing

Overview of series

A Series:

- Standard pumps (1 bar)
- Pumping speeds of 250 to 25,000 m³/h
- Shaft seals
- Gray cast iron (GG)

AD Series:

- Pressure-surge resistant (16 bar)
- Pumping speeds of 500 to 6,000 m³/h
- Shaft seals
- Nodular graphite cast iron (GGG 40.3)

AM Series:

- Standard pumps (1 bar)
- Pumping speeds of 250 to 6,000 m³/h
- Hermetically sealed thanks to magnetic coupling
- Gray cast iron (GG)

ADM Series:

- Pressure-surge resistant (16 bar)
- Pumping speeds of 500 to 6,000 m³/h
- Hermetically sealed thanks to magnetic coupling
- Nodular graphite cast iron (GGG 40.3)

ADx Series:

- Explosion hazard protected: Zone 2, outside (European Union Directive 94/9/EC (-i) / II 3G IIB T3 (o)))
- Pumping speeds of 500 to 4,000 m³/h
- With and without ATEX-certified motor
- Nodular graphite cast iron (GGG 40.3)
- ATEX-certified coupling

ADEx Series:

- Explosion hazard protected: Zone 1, inside and outside (European Union Directive 94/9/EC (II 2G IIB T3 (i) (o)))
- Pumping speeds of 500 to 4,000 m³/h
- With and without ATEX-certified motor
- PTFE-sealed
- Integrated ATEX-certified temperature sensor
- Nodular graphite cast iron (GGG 40.3)
- ATEX-certified coupling
- Can be switched on at 800 mbar without bypass – no need for additional valves

Integral magnetic coupling

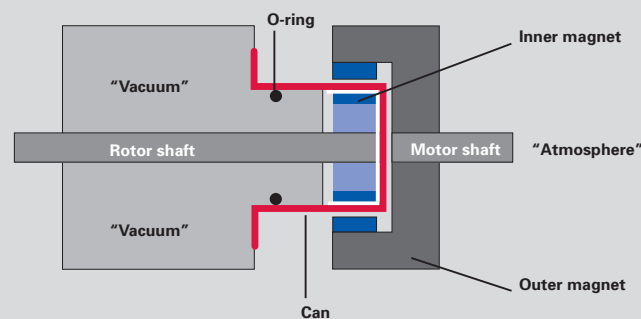

Wide variety of applications

	Roots pumps, sealed with shaft sealing ring		Roots pumps, hermetically sealed		Roots pumps, ATEX series	
	A Series Standard pump (1 bar), gray cast iron (GG), ISO-F flange	AD Series Pressure-surge resistant pump (16 bar), nodular graphite cast iron (GGG 40.3), DIN PN 16 flange	AM Series Standard pump (1 bar), gray cast iron (GG), ISO-F flange	ADM Series Pressure-surge resistant pump (16 bar), nodular graphite cast iron (GGG 40.3)/DIN PN 16 flange	ADx Series Pressure-surge resistant pump (16 bar), nodular graphite cast iron (GGG 40.3), DIN PN 16 flange	ADEx Series Pump without otor, PTFE-sealed, Explosion-hazard protected
Semiconductor						
EUV lithography			●	●		
CVD		●	●			
PVD		●	●			
Ion implantation			●	●		
Load-locks / transfer chambers			●	●		
Flat-panel displays			●	●		
Research & development						
Fusion reactors	▲	●	▲	●		
Space simulation chambers	●	▲	●	▲		
Accelerators	●	▲	●	▲		
High-purity gas applications			●	▲		
Coating						
Ophthalmics	●	▲	●	▲	▲	▲
Wear protection	●	▲	●	▲	▲	▲
Large-surface coating	●	▲	●	▲	▲	▲
Decorative coating	●	▲	●	▲	▲	▲
Photovoltaics	●	▲	●	▲		
Industry/chemistry						
Processes involving toxic gases			●	●	*	*
Processes involving aggressive gases		●		●	*	*
Processes in explosive environments – involving explosive gases					●	●
Electron beam welding	●	▲	●	▲		
Packaging industry	●	▲	●	▲		
Central vacuum supply systems	●	▲	●	▲		
Bottling industry/bottling systems	●	▲	●	▲		
Metallurgy	●	▲	●	▲	▲	▲
Leak detection systems	●	▲	●	▲		
Lamp/ tube manufacturing	●	▲	●	▲		
Freeze-drying systems	●	▲	●	▲		
Metal degassing	●	▲	●	▲		
Transformer drying	●	▲	●	▲		
Oil regeneration	●	▲	●	▲	▲	▲

● Recommended ▲ Possible * Upon request

The Power Pump Portfolio. Roots Pumps for Every Low and Medium Vacuum Application.

Dimensions

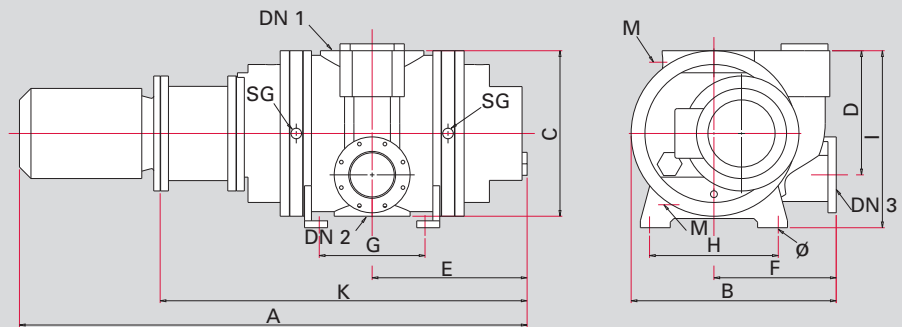

SG = Sealing gas connection 3/8"

Dimensions in mm

Pumpentyp	Okta 250 ¹⁾	Okta 500	Okta 1000	Okta 2000	Okta 4000	Okta 4000	Okta 6000
					50 Hz	60 Hz	
A (A/AD)	770	920	1,126	1,310	1,570	1,630	1,860
A (AM/ADM)	800	950	1,140	1,330	1,630	1,710	1,960
B	323	323	446	502	655	655	655
C	280	280	360	420	510	510	510
D	–	–	270	325	390	390	390
E	220	275	337	373	453	453	578
F	–	–	266	292	400	400	400
G	170	170	230	250	400	400	400
H	220	220	280	360	450	450	450
I	285	285	385	440	542	542	542
K (A/AD)	517	627	784	886	1,069	1,069	1,319
K (AM/ADM)	547	657	798	906	1,131	1,156	1,406
Ø	12	12	11	18	18	18	18
DN 1	DN 63 ISO-F	DN 100 ISO-F	DN 160 ISO-F	DN 160 ISO-F	DN 250 ISO-F	DN 250 ISO-F	DN 250 ISO-F
DN 2	DN 63 ISO-F	DN 100 ISO-F	DN 100 ISO-F	DN 100 ISO-F	DN 160 ISO-F	DN 160 ISO-F	DN 160 ISO-F
DN 3	–	–	DN 100 ISO-F	DN 100 ISO-F	DN 160 ISO-F	DN 160 ISO-F	DN 160 ISO-F

¹⁾ Okta 250 not available in AD or ADM version

Pumping speed

- **Okta 250**
(Dual-stage backing pump 65 m³/h)
- **Okta 500**
(Dual-stage backing pump 120 m³/h)
- **Okta 1000**
(Dual-stage backing pump 250 m³/h)
- **Okta 2000**
(Single-stage backing pump 630 m³/h)
- **Okta 4000**
(Backing pump 1.100 m³/h)
- **Okta 6000**
(Backing pump 1.100 m³/h)
- **Okta 8000**
(Backing pump 1.600 m³/h)

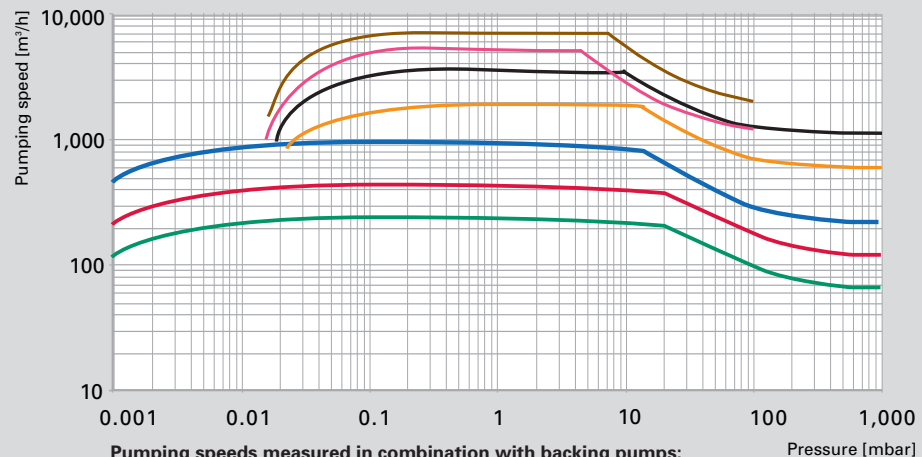

Pumping speeds measured in combination with backing pumps:
Okta 250 A – 1000 A in combination with two-stage backing pumps
Okta 2000 A – 8000 in combination with single-stage backing pumps

Accessories

The scope of delivery of our Roots pumps includes the bolts, nuts and seals for the connection flanges. If the pumps are supplied without a motor, the motor lantern, coupling and connection kit for mounting the motor will be included. An initial charge of P3 or D1 operating fluid will be included for standard applications in the scope of delivery.

Operating fluid/lubricant

For lubricating the gears and bearings.

Sealing gas supply kit

To protect the operating fluid and components in the oil chambers.

Gear chamber evacuation kit

To save time in connection with high-speed evacuation in less than one minute.

Flushing kit

Suitable for processes that tend to form deposits in the pump chambers. The design and composition of this kit will be customized for your specific application. In our standard pumps, flushing necessitates the employment of a sealing gas to prevent fluids from reaching the oil chambers.

PTFE sealing material

Especially resistant to aggressive media.

Accessories	Order number
Splinter shield, for Okta 250 A/AM	PK 300 010-X
Splinter shield, for Okta 500 A/AM	PP 030 149 AX
Splinter shield, for Okta 500 AD/ADM	PP 042 350-X
Splinter shield, for Okta 1000/2000 A/AM	PP 031 114-X
Splinter shield, for Okta 1000 AD/2000 AD/ADM	PP 031 115-X
Splinter shield, for Okta 4000/6000 A/AM	PP 031 136-X
Splinter shield, for Okta 4000 AD/6000 AD/ADM	PP 031 137-X
Splinter shield, for Okta 8000/12000	PP 030 152-X
Splinter shield, for Okta 18000/25000	PP 030 336-T

Operating fluid	Order number
0.5 l P3 Mineral oil	PK 001 136-T
1 l P3 Mineral oil	PK 001 106-T
5 l P3 Mineral oil	PK 001 107-T
20 l P3 Mineral oil	PK 001 108-T
50 l P3 Mineral oil	PK 001 109-T
200 l P3 Mineral oil	PK 001 110-T

0.5 l F5 Perfluorpolyether ¹⁾	PK 001 851-T
1 l F5 Perfluorpolyether ¹⁾	PK 001 852-T
5 l F5 Perfluorpolyether ¹⁾	PK 001 853-T
20 l F5 Perfluorpolyether ¹⁾	PK 001 854-T
50 l F5 Perfluorpolyether ¹⁾	PK 001 855-T

0.5 l D1 Oil ¹⁾	PK 005 881-T
1 l D1 Oil ¹⁾	PK 005 875-T
5 l D1 Oil ¹⁾	PK 005 876-T
20 l D1 Oil ¹⁾	PK 005 877-T
50 l D1 Oil ¹⁾	PK 005 878-T
200 l D1 Oil ¹⁾	PK 005 879-T

More accessories on request; ¹⁾ for AM/ADM versions only

The Power Pump Portfolio. Roots Pumps for Every Low and Medium Vacuum Application.

Technical data and order numbers

Pump type	Okta 250 A			Okta 500 A	
	Motor with 50 Hz	Motor with 60 Hz	without motor	Motor with 50 Hz	Motor with 60 Hz
Connection flange*					
inlet	DN 63 ISO-F	DN 63 ISO-F	DN 63 ISO-F	DN 100 ISO-F	DN 100 ISO-F
outlet	DN 63 ISO-F	DN 63 ISO-F	DN 63 ISO-F	DN 100 ISO-F	DN 100 ISO-F
outlet, on the side	–	–	–	DN 100 ISO-F	DN 100 ISO-F
Nominal pumping speed	270 m ³ /h	324 m ³ /h	–	490 m ³ /h	588 m ³ /h
Differential pressure					
at the overflow valve	75 mbar	75 mbar	75 mbar	75 mbar	75 mbar
at the overflow valve ADEx	–	–	–	53 mbar	–
Emission sound pressure level (EN ISO 2151)					
at intake pressure 1 mbar	70 dB(A)	70 dB(A)	70 dB(A)	70 dB(A)	70 dB(A)
at intake pressure 10 mbar	75 dB(A)	75 dB(A)	75 dB(A)	75 dB(A)	75 dB(A)
Leak rate					
Pumps with shaft sealing	1 · 10 ⁻² mbar l/s	1 · 10 ⁻² mbar l/s	1 · 10 ⁻² mbar l/s	1 · 10 ⁻² mbar l/s	1 · 10 ⁻² mbar l/s
Magnetic coupled pumps	1 · 10 ⁻⁵ mbar l/s	1 · 10 ⁻⁵ mbar l/s	1 · 10 ⁻⁵ mbar l/s	1 · 10 ⁻⁵ mbar l/s	1 · 10 ⁻⁵ mbar l/s
Pump fluid filling	1.5 l	1.5 l	1.5 l	1.5 l	1.5 l
Motor rating	0.75 kW	1.1 kW	–	1.5 kW	2.2 kW
Rotational speed	3,000 1/min	3,600 1/min	–	3,000 1/min	3,600 1/min
Power supply: Voltage**	230/400 V, 50 Hz	230/400 V, 60 Hz	–	230/400 V, 50 Hz	230/400 V, 60 Hz
Weight	95 kg	95 kg	85 kg	125 kg	125 kg
Order numbers					
A Series	PP W21 000	PP W21 002	PP W21 001	PP W31 000	PP W31 002
AD Series	–	–	–	PP W31 700	PP W31 702
AM Series	PP W22 000	PP W22 002	PP W22 001	PP W32 000	PP W32 002
ADM Series	–	–	–	PP W32 700	PP W32 702
ADx Series	–	–	–	PP W33 200	PP W33 202
ADEx Series	–	–	–	PP W33 000	–

* Connection flanges of series AD, ADM, ADx and ADEx according to EN1092-1/DIN2633, PN 16; raised face according to DIN2526, Form A

** Range: ± 10%

without motor	Okta 1000 A			Okta 2000 A		
	Motor with 50 Hz	Motor with 60 Hz	without motor	Motor with 50 Hz	Motor with 60 Hz	without motor
DN 100 ISO-F	DN 160 ISO-F	DN 160 ISO-F	DN 160 ISO-F	DN 160 ISO-F	DN 160 ISO-F	DN 160 ISO-F
DN 100 ISO-F	DN 100 ISO-F	DN 100 ISO-F	DN 100 ISO-F	DN 100 ISO-F	DN 100 ISO-F	DN 100 ISO-F
DN 100 ISO-F	DN 100 ISO-F	DN 100 ISO-F	DN 100 ISO-F	DN 100 ISO-F	DN 100 ISO-F	DN 100 ISO-F
–	1,070 m ³ /h	1,284 m ³ /h	–	2,065 m ³ /h	2,478 m ³ /h	–
75 mbar	45 mbar	45 mbar	45 mbar	35 mbar	35 mbar	35 mbar
53 mbar	30 mbar	–	30 mbar	20 mbar	–	20 mbar
70 dB(A)	72 dB(A)	72 dB(A)	72 dB(A)	72 dB(A)	72 dB(A)	72 dB(A)
75 dB(A)	75 dB(A)	75 dB(A)	75 dB(A)	75 dB(A)	75 dB(A)	75 dB(A)
1 · 10 ⁻² mbar l/s	1 · 10 ⁻² mbar l/s	1 · 10 ⁻² mbar l/s	1 · 10 ⁻² mbar l/s	1 · 10 ⁻² mbar l/s	1 · 10 ⁻² mbar l/s	1 · 10 ⁻² mbar l/s
1 · 10 ⁻⁵ mbar l/s	1 · 10 ⁻⁵ mbar l/s	1 · 10 ⁻⁵ mbar l/s	1 · 10 ⁻⁵ mbar l/s	1 · 10 ⁻⁵ mbar l/s	1 · 10 ⁻⁵ mbar l/s	1 · 10 ⁻⁵ mbar l/s
1.5 l	2.9 l	2.9 l	2.9 l	5 l	5 l	5 l
–	3 kW	4 kW	–	5.5 kW	5.8 kW	–
–	3,000 1/min	3,600 1/min	–	3,000 1/min	3,600 1/min	–
–	230/400 V, 50 Hz	230/400 V, 60 Hz	–	230/400 V, 50 Hz	230/400 V, 60 Hz	–
100 kg	250 kg	250 kg	220 kg	370 kg	370 kg	310 kg
PP W31 001	PP W41 000	PP W41 002	PP W41 001	PP W61 000	PP W61 002	PP W61 001
PP W31 701	PP W41 700	PP W41 702	PP W41 701	PP W61 700	PP W61 702	PP W61 701
PP W32 001	PP W42 000	PP W42 002	PP W42 001	PP W62 000	PP W62 002	PP W62 001
PP W32 701	PP W42 700	PP W42 702	PP W42 701	PP W62 700	PP W62 702	PP W62 701
PP W33 201	PP W43 200	PP W43 202	PP W43 201	PP W63 200	PP W63 202	PP W63 201
PP W31 840	PP W43 000	–	PP W41 950	PP W63 000	–	PP W61 800

The Power Pump Portfolio. Roots Pumps for Every Low and Medium Vacuum Application.

Technical data and order numbers

Pump type	Okta 4000 A			Okta 6000 A	
	Motor with 50 Hz	Motor with 60 Hz	without motor	Motor with 50 Hz	Motor with 60 Hz
Connection flange*					
inlet	DN 250 ISO-F	DN 250 ISO-F	DN 250 ISO-F	DN 250 ISO-F	DN 250 ISO-F
outlet	DN 160 ISO-F	DN 160 ISO-F	DN 160 ISO-F	DN 160 ISO-F	DN 160 ISO-F
outlet, on the side	DN 160 ISO-F	DN 160 ISO-F	DN 160 ISO-F	DN 160 ISO-F	DN 160 ISO-F
Nominal pumping speed	4,050 m ³ /h	4,860 m ³ /h	–	6,075 m ³ /h	7,290 m ³ /h
Differential pressure					
at the overflow valve	25 mbar	25 mbar	25 mbar	20 mbar	20 mbar
at the overflow valve ADEx	20 mbar	–	20 mbar	–	–
Emission sound pressure level (EN ISO 2151)					
at intake pressure 1 mbar	74 dB(A)	74 dB(A)	74 dB(A)	74 dB(A)	74 dB(A)
at intake pressure 10 mbar	79 dB(A)	79 dB(A)	79 dB(A)	79 dB(A)	79 dB(A)
Leak rate					
Pumps with shaft sealing	1 · 10 ⁻² mbar l/s	1 · 10 ⁻² mbar l/s	1 · 10 ⁻² mbar l/s	1 · 10 ⁻² mbar l/s	1 · 10 ⁻² mbar l/s
Magnetic coupled pumps	1 · 10 ⁻⁵ mbar l/s	1 · 10 ⁻⁵ mbar l/s	1 · 10 ⁻⁵ mbar l/s	1 · 10 ⁻⁵ mbar l/s	1 · 10 ⁻⁵ mbar l/s
Pump fluid filling	6.8 l	6.8 l	6.8 l	6.8 l	6.8 l
Motor rating	11 kW	15 kW	–	15 kW	18.5 kW
Rotational speed	3,000 1/min	3,600 1/min	–	3,000 1/min	3,600 1/min
Power supply: Voltage**	400 V, 50 Hz	400 V, 60 Hz	–	400 V, 50 Hz	400 V, 60 Hz
Weight	600 kg	600 kg	520 kg	850 kg	850 kg
Order numbers					
A Series	PP W71 000	PP W71 004	PP W71 001	PP W76 000	PP W76 004
AD Series	PP W71 700	PP W71 704	PP W71 701	PP W76 700	PP W76 704
AM Series	PP W72 000	PP W72 002	PP W72 001	PP W77 000	PP W77 002
ADM Series	PP W72 700	PP W72 702	PP W72 701	PP W77 700	PP W77 702
ADx Series	PP W73 200	PP W73 202	PP W73 201	–	–
ADEx Series	PP W73 000	–	PP W71 990	–	–

* Connection flanges of series AD, ADM, ADx and ADEx according to EN1092-1/DIN2633, PN 16; raised face according to DIN2526, Form A

** Range: ± 10%

without motor	Okta 8000			Okta 18000		
	Motor with 50 Hz	Motor with 60 Hz	without motor	Motor with 50 Hz	Motor with 60 Hz	without motor
DN 250 ISO-F	DN 320 ISO-F	DN 320 ISO-F	DN 320 ISO-F	DN 400 PN 10	DN 400 PN 10	DN 400 PN 10
DN 160 ISO-F	DN 320 ISO-F	DN 320 ISO-F	DN 320 ISO-F	DN 400 PN 10	DN 400 PN 10	DN 400 PN 10
DN 160 ISO-F	DN 250 ISO-F	DN 250 ISO-F	DN 250 ISO-F	DN 320 ISO-F	DN 320 ISO-F	DN 320 ISO-F
–	8,000 m ³ /h	9,600 m ³ /h	–	17,850 m ³ /h	21,420 m ³ /h	–
20 mbar	27 mbar	27 mbar	27 mbar	10 mbar	10 mbar	10 mbar
–	–	–	–	–	–	–
74 dB(A)	74 dB(A)	74 dB(A)	74 dB(A)	75 dB(A)	75 dB(A)	75 dB(A)
79 dB(A)	78 dB(A)	78 dB(A)	78 dB(A)	79 dB(A)	79 dB(A)	79 dB(A)
1 · 10 ⁻² mbar l/s	1 · 10 ⁻² mbar l/s	1 · 10 ⁻² mbar l/s	1 · 10 ⁻² mbar l/s	1 · 10 ⁻² mbar l/s	1 · 10 ⁻² mbar l/s	1 · 10 ⁻² mbar l/s
1 · 10 ⁻⁵ mbar l/s	–	–	–	–	–	–
6.8 l	21 l	21 l	21 l	68 l	68 l	68 l
–	22 kW	30 kW	–	45 kW	55 kW	–
–	1,500 1/min	1,800 1/min	–	1,500 1/min	1,800 1/min	–
–	400 V, 50 Hz	400 V, 60 Hz	–	400 V, 50 Hz	400 V, 60 Hz	–
750 kg	1,550 kg	1,600 kg	1,400 kg	3,300 kg	3,300 kg	2,800 kg
PP W76 001	PP W80 000	PP W80 060	PP W80 001	PP W90 000	PP W90 060	PP W90 001
PP W76 701	–	–	–	–	–	–
PP W77 001	–	–	–	–	–	–
PP W77 701	–	–	–	–	–	–
–	–	–	–	–	–	–
–	–	–	–	–	–	–

**Leading. Dependable.
Customer Friendly.**

Pfeiffer Vacuum stands for innovative and custom vacuum solutions worldwide, for German engineering art, competent advice and reliable service.

Ever since the invention of the turbopump, we have been setting standards in our industry and this claim to leadership will continue to drive us in the future.

**Are you looking for a
perfect vacuum solution?
Please contact us:**

Pfeiffer Vacuum GmbH
Headquarters · Germany
T +49 6441 802-0
info@pfeiffer-vacuum.de
www.pfeiffer-vacuum.com