



## PrismaPro®

The latest generation of compact mass spectrometers.  
Modular design. Powerful software.  
Low detection limit.

# PrismaPro®

The latest generation of compact mass spectrometers.



Your added value



Optimum adaptability  
due to  
modular design

The combination of high sensitivity, maximum stability and intelligent operation make the PrismaPro the perfect solution for mass spectrometry.

### **Versatility**

Its modular design offers you a variety of application options in industrial and analytical environments, in research & development, in semiconductor production and in coating technology.

The PrismaPro is the ideal solution for applications ranging from quality assurance, leak detection and residual gas analysis right through to complex, quantitative tasks.

### **New generation of software**

The newly developed PV MassSpec software is a further plus. In addition to being especially easy to operate, it also serves as an easy-to-read platform for transferring all measured data.

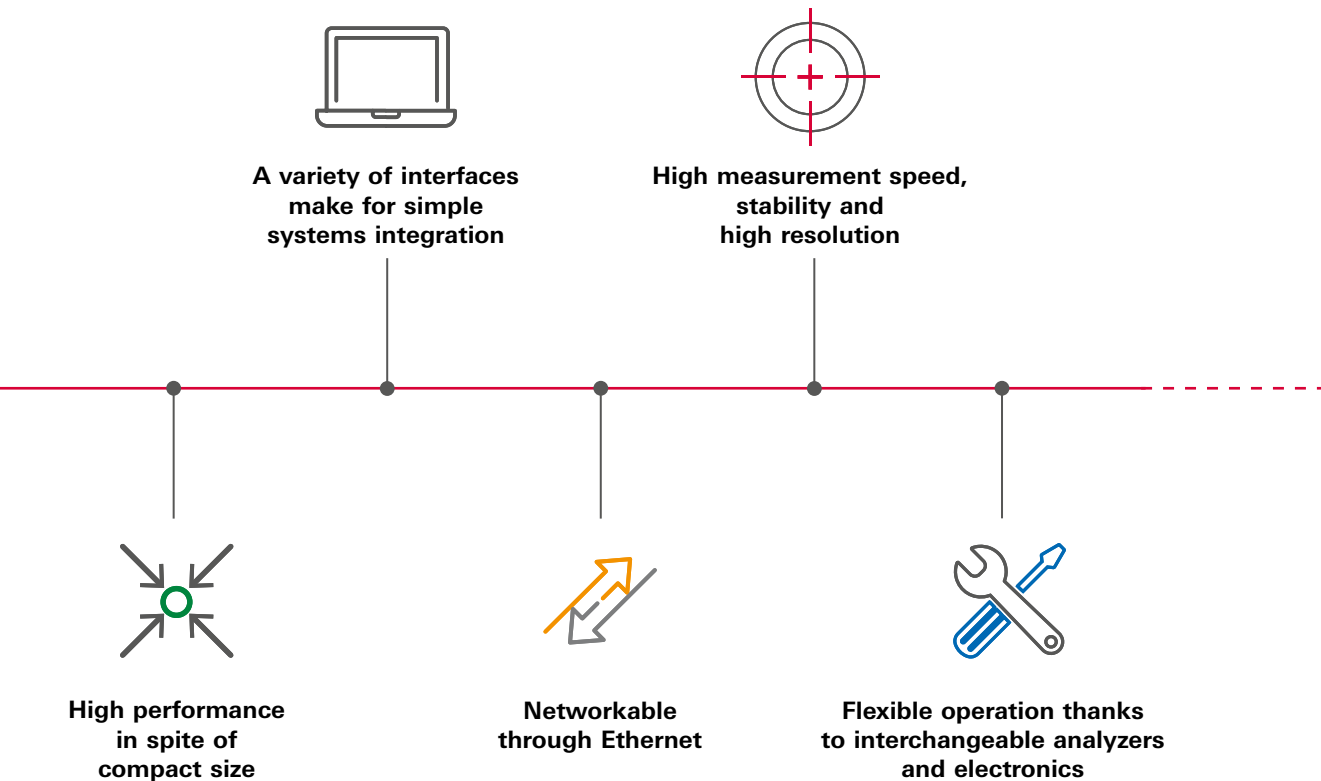

### Open programming interface

Alternatively to the PV MassSpec, the JSON programming interface of the PrismaPro can also be accessed directly. Together with a wide selection of interfaces, such as digital and analog inputs and outputs or Ethernet, integration into your system is easily achieved. Alternatively, we can offer you a ready-made application to connect the mass spectrometer to your PLC (see page 11).

Our product and service professionals around the world stand ready to provide you with application assistance on the implementation of the PrismaPro. Many decades of customer and application-specific experiences make Pfeiffer Vacuum your ideal partner.

### Customer values

- Two filaments mean maximum up-time
- Lowest detectable partial pressure  $3 \cdot 10^{-15}$  hPa (mbar)
- Easy total pressure measurement due to directly connectable gauges
- Saving of time through intuitive operation of the PV MassSpec software
- World-class support and worldwide on-site service
- Easy integration thanks to open JSON programming interface

# PrismaPro®

## PV MassSpec – new Software for PrismaPro®

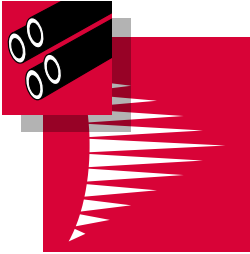

### Customer values

- User-friendly, intuitive operation
- Automated measurement routines via included sequencer
- Leak detection and vacuum diagnosis with just one click
- Automatic calibration and tuning
- Simple definition of measurement recipes
- Mass spectrometer data can be linked with external signals

The PV MassSpec software has been specifically developed for the PrismaPro and offers an easy-to-read, user-friendly platform for capturing and visualizing measured data and parameter records. Complete measurement procedures can be programmed.

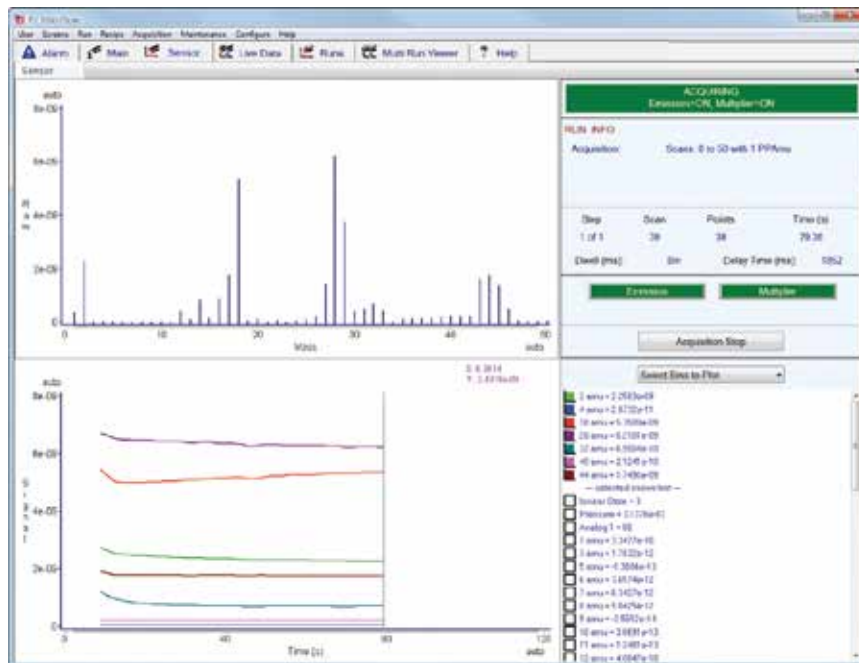

PV MassSpec measurement routine

**Overview of technologies**

**Biased ionization chamber**

Biasing the ionization chamber results in an extremely low background signal. The electron-emitting filament is positively biased relative to ground. This design prevents desorption of gas particles from the chamber walls, and thus the generation of an undesired background signals by electron stimulated desorption.

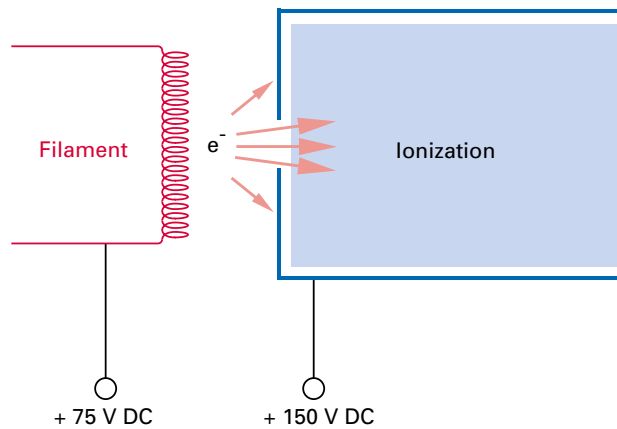

**Field-axis technology**

One of the most important factors in the performance of a mass spectrometer is the transmission of the ions from the ion source into the mass filter. With the aid of field-axis technology, the ions are able to cross the peripheral fields of the separating system without any noteworthy interaction. This enables a high level of sensitivity (A/hPa) to be achieved without the need for pre and post filters.

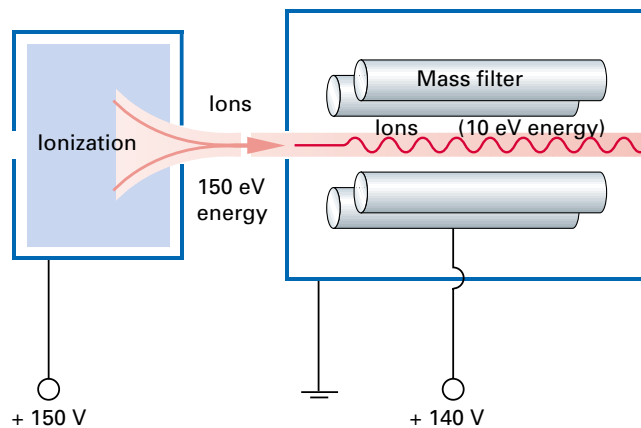

# PrismaPro®

## Dimensions

### Dimensions

QMG 250 F 0° (Faraday) open ion source

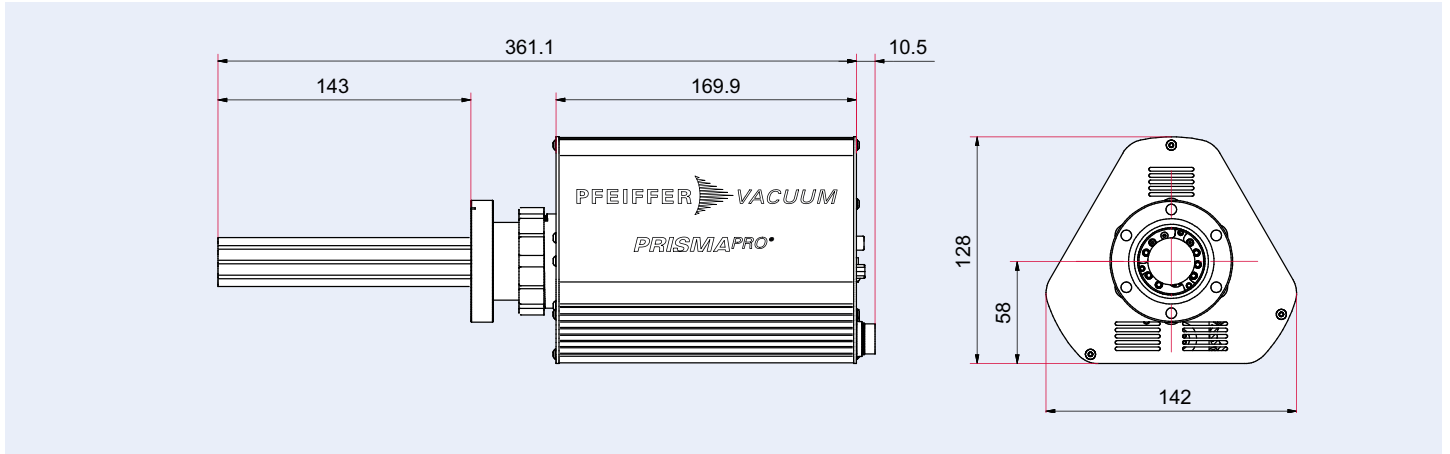

QMG 250 F 90° (Faraday) open ion source

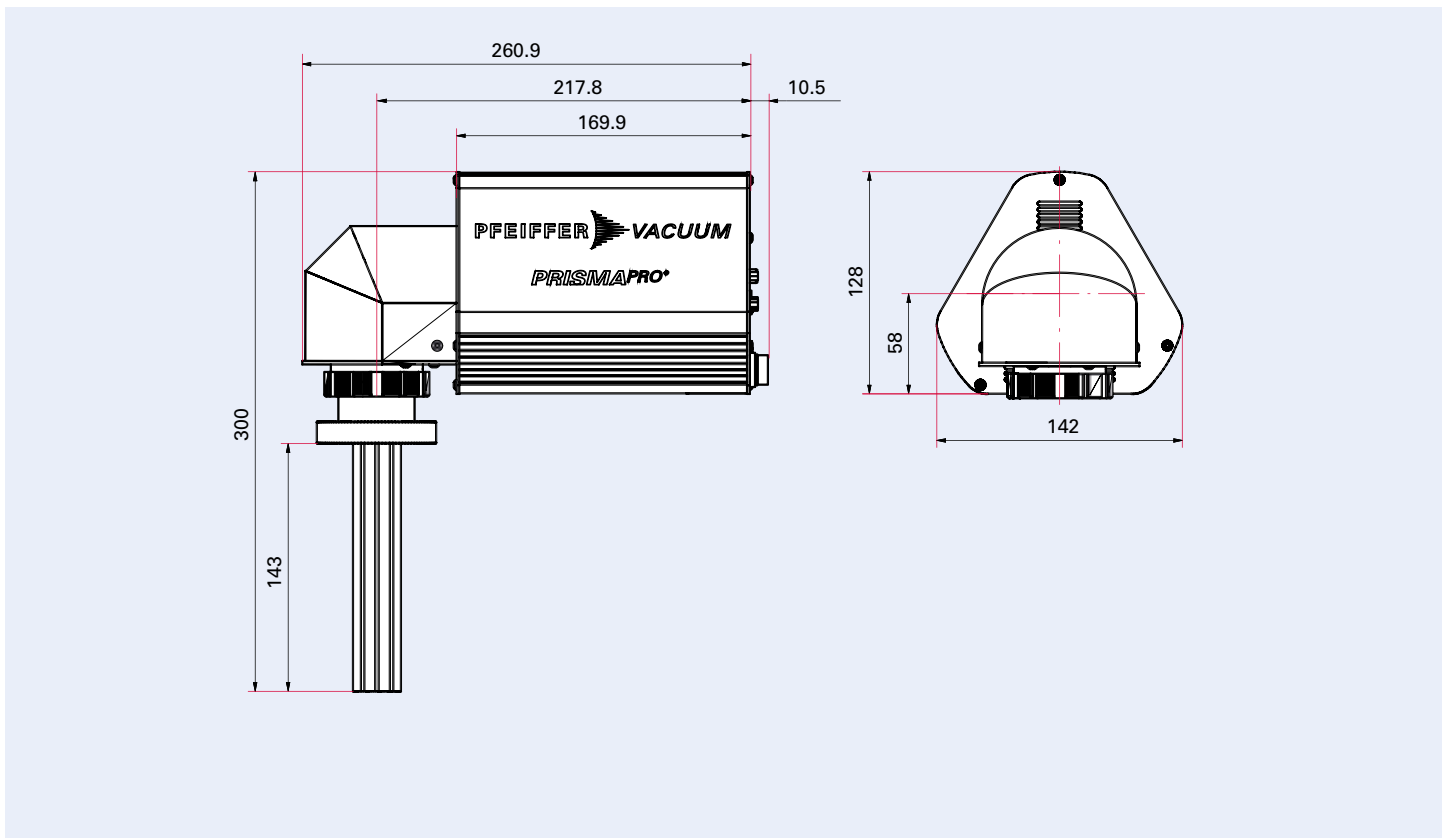

Make sure that the flange or tube has an inner diameter of  $\geq 37$  mm, better  $\geq 39$  mm.

QMG 250 M 0° (C-SEM/Faraday) open ion source

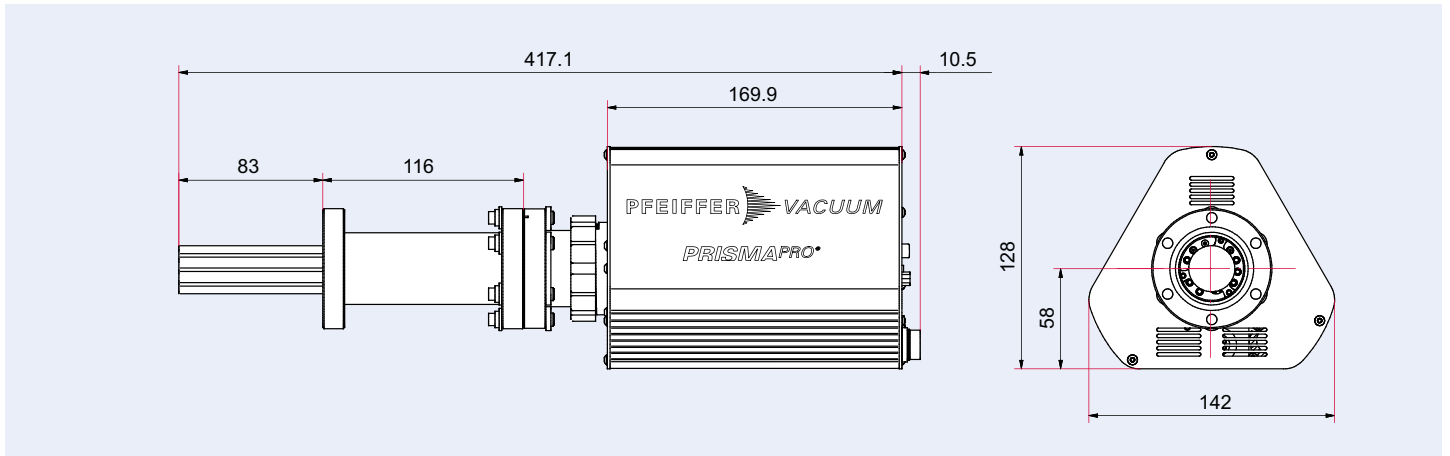

QMG 250 M 90° (C-SEM/Faraday) open ion source

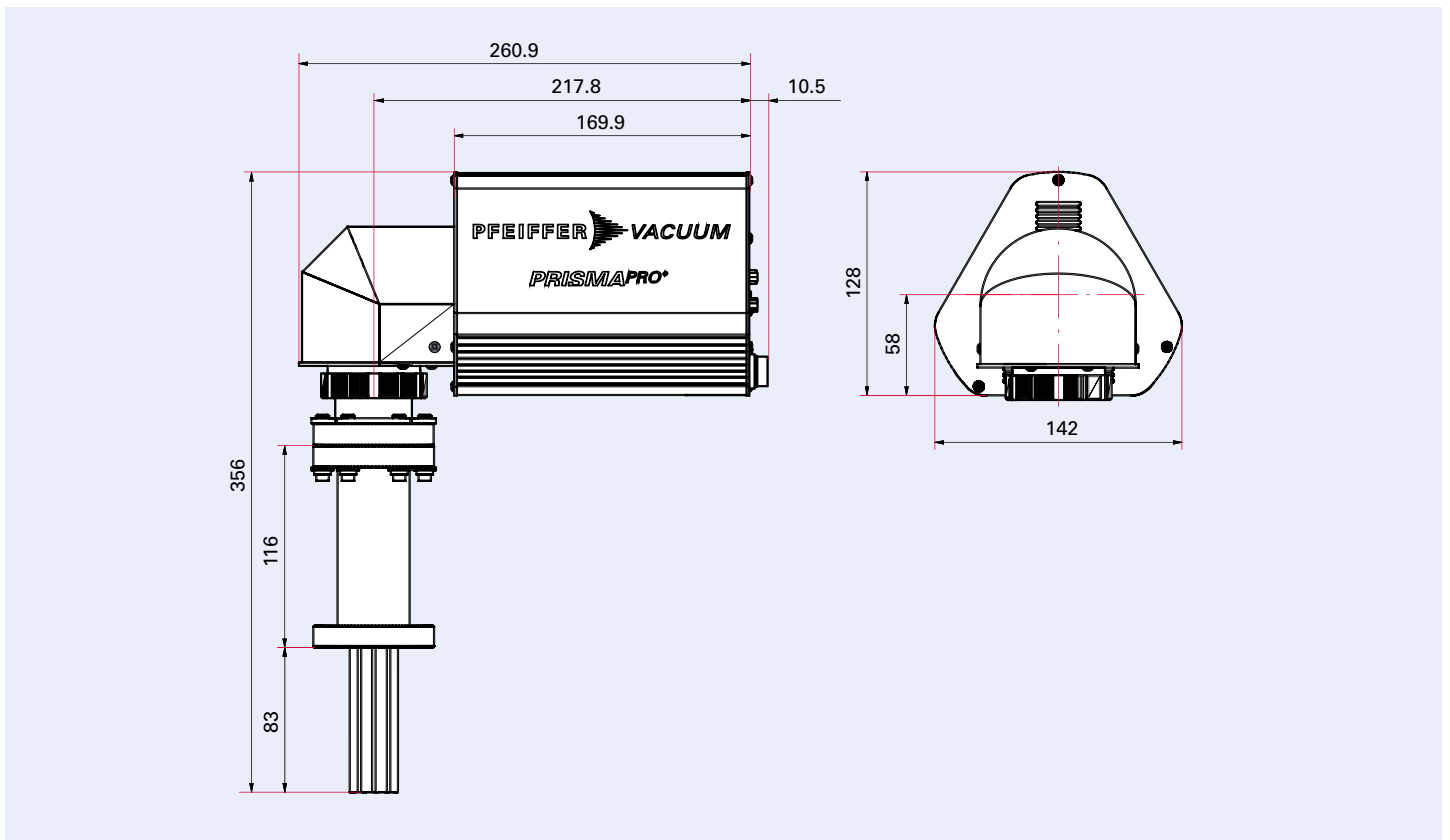

## Connection options

### Connection options

#### Standard

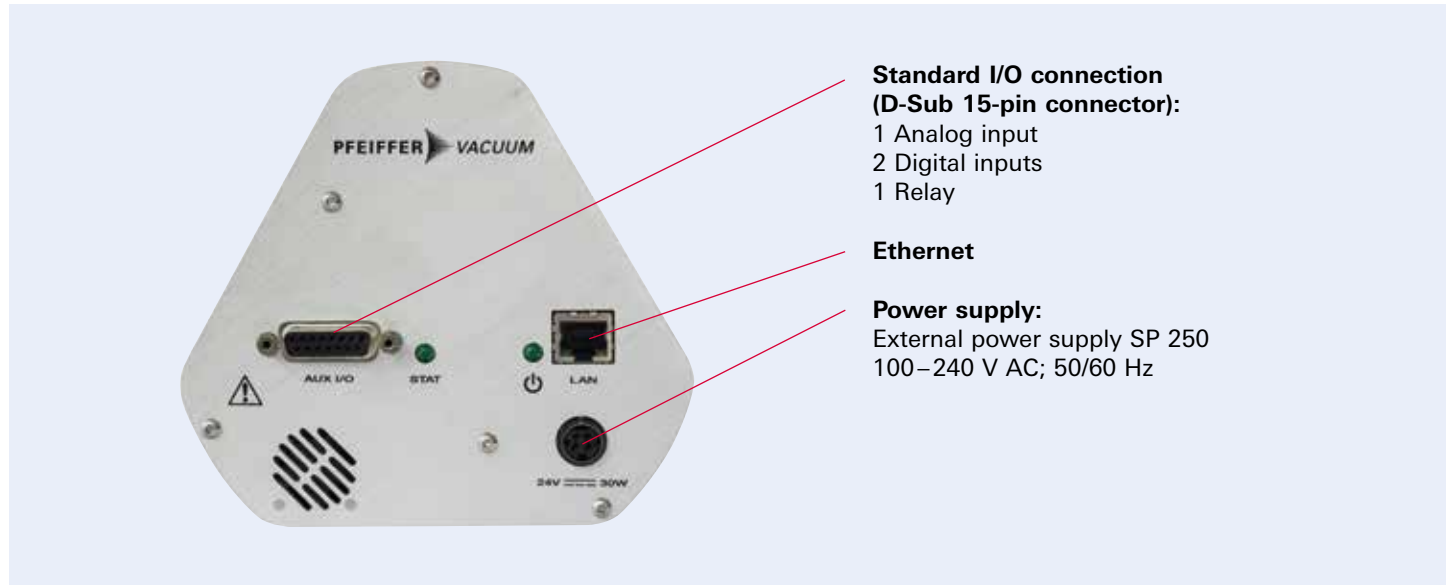

**Standard I/O connection (D-Sub 15-pin connector):**  
 1 Analog input  
 2 Digital inputs  
 1 Relay

**Ethernet**

**Power supply:**  
 External power supply SP 250  
 100–240 V AC; 50/60 Hz

#### Extended

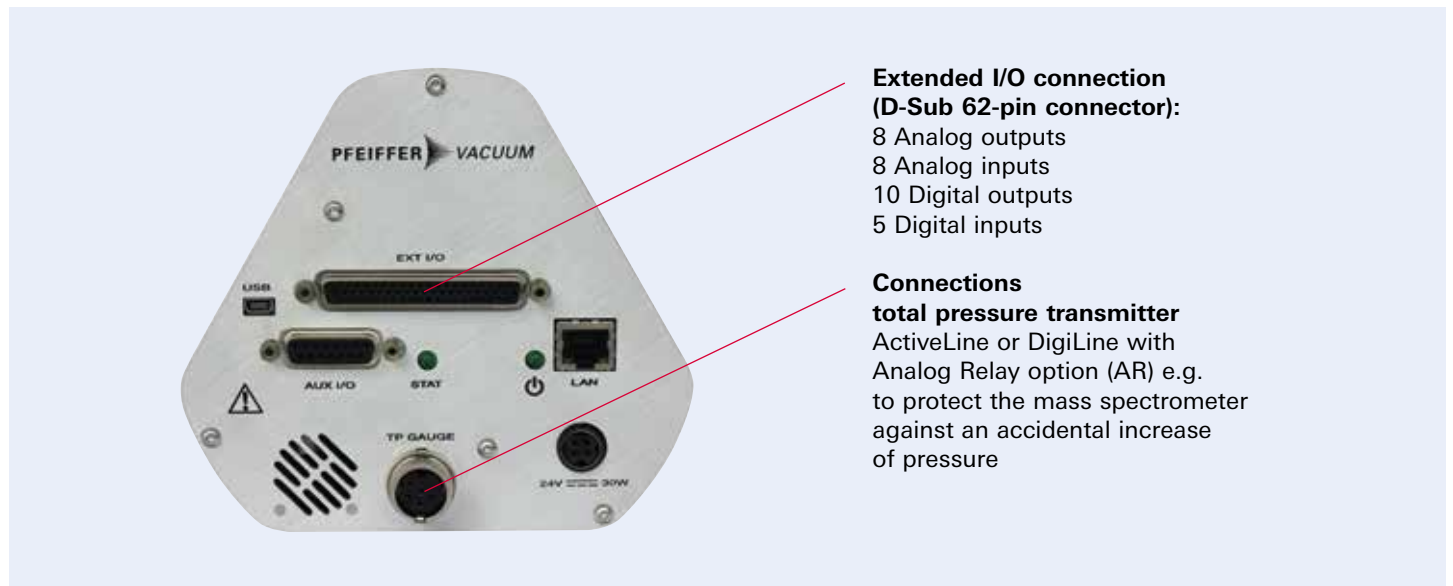

**Extended I/O connection (D-Sub 62-pin connector):**  
 8 Analog outputs  
 8 Analog inputs  
 10 Digital outputs  
 5 Digital inputs

**Connections**  
**total pressure transmitter**  
 ActiveLine or DigiLine with  
 Analog Relay option (AR) e.g.  
 to protect the mass spectrometer  
 against an accidental increase  
 of pressure

I/O option	Analog outputs	Analog inputs	Digital outputs	Digital inputs
Number	8	8	10	5
Specification	0–10 V	-10 – +10 V	$V_{out} = 24 V$	$V_{in} = 24 V$
Resolution	16 bit	16 bit	–	–
Application examples	<ul style="list-style-type: none"> <li>Measured values, e.g. ion currents</li> <li>Data transfer to higher-level systems</li> </ul>	Collecting external data values, e.g. pressure, temperature, gas flow	<ul style="list-style-type: none"> <li>Free assignment of switchpoints</li> <li>Valve actuation</li> </ul>	Starting or stopping measurement tasks by external signal



### Technical data

	QMG 250 F1	QMG 250 F2	QMG 250 F3	QMG 250 M1	QMG 250 M2	QMG 250 M3
Detector	Faraday (F)			C-SEM/Faraday (M)		
Mass range	1–100 u	1–200 u	1–300 u	1–100 u	1–200 u	1–300 u
Rod system, diameter/length	6 mm / 125 mm					
Min. detection limit, Faraday <sup>1)2)</sup>	$4 \cdot 10^{-13}$ hPa	$5 \cdot 10^{-13}$ hPa	$7 \cdot 10^{-13}$ hPa			
Min. detection limit, C-SEM <sup>1)2)</sup>	–	–	–	$3 \cdot 10^{-15}$ hPa	$4 \cdot 10^{-15}$ hPa	$5 \cdot 10^{-15}$ hPa
Ar sensitivity, Faraday <sup>3)</sup>	$5 \cdot 10^{-4}$ A/hPa	$4 \cdot 10^{-4}$ A/hPa	$3 \cdot 10^{-4}$ A/hPa	$5 \cdot 10^{-4}$ A/hPa	$4 \cdot 10^{-4}$ A/hPa	$3 \cdot 10^{-4}$ A/hPa
Max. operating pressure, Faraday operation	$5 \cdot 10^{-4}$ hPa					
Max. operating pressure, C-SEM operation	–	–	–	$5 \cdot 10^{-5}$ hPa	$5 \cdot 10^{-5}$ hPa	$5 \cdot 10^{-5}$ hPa
Contribution to adjacent mass (40/41) <sup>1)</sup>	< 10 ppm	< 20 ppm	< 50 ppm	< 10 ppm	< 20 ppm	< 50 ppm
Operating temperature, analyzer	200 °C (max. 150 °C when operating with SEM)					
Operating temperature, electronics	5 – 50 °C					
Bakeout temperature, analyzer	300 °C (electronics removed)					
Connection flange	DN 40 CF-F					
Resolution at 10 % peak height	0,5 – 2,5 u					
Dwell time	1 ms – 16 s/u					
Reproducibility of peak ratio	± 0,5 %					
Interface	Ethernet					
Supply voltage	100–240 V AC, 50/60 Hz					
Weight	2,5 kg			3,2 kg		

<sup>1)</sup> Only for open ion source

<sup>2)</sup> At a dwell time of 4s

<sup>3)</sup> Considerably higher sensitivity by operation with C-SEM

# PrismaPro®

## Order matrix and Accessories

### Order matrix PrismaPro®

### Order number PT M1a bcd 2fg

Detector version	a
<b>Faraday<sup>1)</sup></b> only for leak detection and high-vacuum residual gas analysis	5
<b>C-SEM/Faraday;</b> C-SEM = Continuous Secondary Electron Multiplier for fast, sensitive UHV residual gas analysis, analytical applications and leak detection	6
Mass range	b
1-100 u	1
1-200 u	2
1-300 u	3
Ion source	c
<b>Open ion source</b> for high-vacuum residual gas analysis; high sensitivity and good linearity	1
<b>Gas-tight ion source</b> for use in combination with gas inlet systems; low gas consumption, high signal-to-noise ratio	2
<b>Crossbeam ion source</b> for direct gas beam inlet, without interaction with the walls of the ion source; electron energy adjustable from 15 to 102 eV	3
<b>Grid ion source<sup>2)</sup></b> for UHV residual gas analysis; minimum outgassing and desorption rate	4
Filament	d
<b>Tungsten;</b> for UHV applications	1
<b>Yttriated iridium;</b> low filament temperatures, high resistance to air inrushes	2
Connection	f
0° (straight)	1
90° (right-angled)	2
I/O connection <sup>3)</sup>	g
<b>Standard</b>	0
<b>Extended</b> for control and signal interchange via analog and digital inputs/outputs and connection to a total pressure gauge	1

<sup>1)</sup> With open ion source only

<sup>2)</sup> Ion sources with tungsten filament only

<sup>3)</sup> See page 8

**Accessories**

For external total pressure measurement <sup>1)</sup>	Order numbers
ActiveLine, PKR 360, $1 \cdot 10^{-9}$ – 1.000 hPa	<b>PT T02 350 010</b>
ActiveLine, PKR 361, $1 \cdot 10^{-9}$ – 1.000 hPa	<b>PT T03 350 010</b>
ActiveLine, PBR 360, $5 \cdot 10^{-10}$ – 1.000 hPa	<b>PT R27 012</b>
ActiveLine, TPR 270, $1 \cdot 10^{-4}$ – 1.000 hPa	<b>PT R26 770</b>
Connection cable, ActiveLine gauge–OMG 250, 0,6 m	<b>PT 448 249 -T</b>
DigiLine, PPT 200 AR, $1 \cdot 10^{-4}$ – 1.000 hPa	<b>PT R38 131</b>
DigiLine, HPT 200 AR, $5 \cdot 10^{-10}$ – 1.000 hPa	<b>PT R39 351</b>
DigiLine, MPT 200 AR, $5 \cdot 10^{-9}$ – 1.000 hPa	<b>PT R40 351</b>
Connection cable, DigiLine gauge–OMG 250, 3 m	<b>PT 348 250 -T</b>

<sup>1)</sup> Can be used only in conjunction with extended I/O connection

For connecting and testing the I/Os	Order numbers
Testbox for Standard I/O-Interface (15-pin Sub-D)	<b>PT 160 303</b>
Connection cable, 15-pin Sub-D, female/male, length: 2 m	<b>PM 071 711 -X</b>
Gender changer, 15-pin Sub-D (male)	<b>PT 160 309</b>
Interface module, 15-pin	<b>PT 160 310</b>
Testbox for Extended I/O-Interface (62-pin Sub-D)	<b>PT 160 304</b>
Connection cable, 62-pin Sub-D, male/male, length: 1.52 m	<b>PT 160 305</b>
Gender changer, 62-pin Sub-D HD (female)	<b>PT 160 306</b>
Interface module, 62-pin	<b>PT 160 307</b>
Banana plugs for testbox, 4 mm, 2.5 mm <sup>2</sup>	<b>PT 160 308</b>
Simulator for ActiveLine gauges, adjustable	<b>PT 583 066 -T</b>



Interface module, 15-pin



Testbox for Standard I/O-Interface (15-pin Sub-D)



Interface module, 62-pin



Testbox for Extended I/O-Interface (62-pin Sub-D)

Miscellaneous	Order numbers
Chamber for PrismaPro with 90° angle, DN 40 CF	<b>K-PV-00001.A</b>
All-metal gas dosing valve, manual, DN 40 CF, gas inlet VCR 1/4"	<b>420VED040-VCR</b>
MPP-License only	<b>PT 160 302</b>
Box-PC IPC127E + MPP-License	<b>PT 160 301</b>
Box-PC IPC227E + MPP-License	<b>PT 160 300</b>

further accessories on request

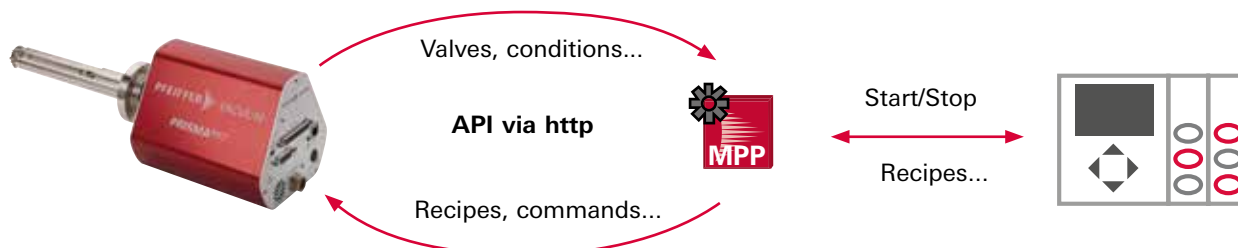

MPP: Application for communication between mass spectrometer PrismaPro and PC/PLC

## Your Success. Our Passion.

We give our best for you every day –  
worldwide!

**Are you looking for an  
optimal vacuum solution?**  
Please contact us:

**Pfeiffer Vacuum GmbH**  
Germany  
T +49 6441 802-0



Errors excepted. All data subject to change without prior notice. PK 0115 PEN (July 2023/POD)

Follow us on social media  
#pfeiffervacuum



[www.pfeiffer-vacuum.com](http://www.pfeiffer-vacuum.com)

**PFEIFFER**  **VACUUM**